

IN FOCUS: Flange Protection



SOLUTIONS FOR FLANGE REPAIR AND PROTECTION

The integrity of flanged connections is critical to the containment of fluids in a piping system. Loss of containment, whether in chemical lines such as hydrocarbons and gas systems or water distribution lines, will have significant environmental, operational and commercial impact, and could pose a serious safety risk.

Corrosion issues of flanges

Crevice corrosion is a common damage mechanism where there is a concentration of corrosive substances in a localised area. Indeed, the rate of corrosion is accelerated by the concentration of corrosive materials within a confined space. The crevice between two flange faces is the ideal environment for crevice corrosion. The flange face is predominantly prone to crevice corrosion when flanges are used in extremely corrosive environments.

Over time, the corrosion started in the gap on the inside diameter of a flange can extend to the gasket area. The concentration of corrosive materials between the gap of the

sealing surface and gasket material can influence the corrosion rate of the flange face. The gasket acts as a seal covering the area of the face from the corner edge to the end of the machined surface of the face. Corrosion of the sealing area can result in a loss of containment and release of product with potentially catastrophic consequences for the environment.

Insufficient external protection on these areas can lead to rapid and more extensive damage to the flanges and fastenings which will accelerate the deterioration of the system's integrity. The consequences of such a situation are not easy to predict since they are dependent upon prevailing conditions. Depending on the severity of the environmental conditions, there may be a slow continuous degradation of the substrate; however, under extreme conditions, the external corrosion process may rapidly reach a point where the structural integrity of the system is adversely affected and could result in a catastrophic loss of containment. ■

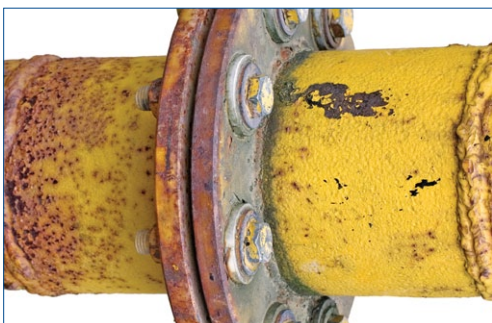

General corrosion on flange

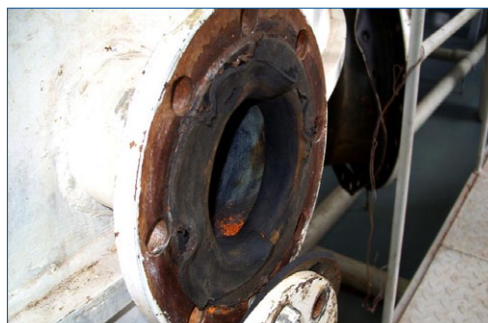

Highly corroded flange face

Issue 109

Contents



Corrosion Issues on Flanges 1

Crevice corrosion damages on faces and gaskets



Belzona Solutions 2

Flange repair and protection



A Safe Flange Repair 3

Belzona reforms 2" 150psi rated flange



52" Flange Protected 4

Belzona 3411 solves corrosion problem in USA

FLANGE FACE INSPECTION

As flanged connections are a critical component within the piping system, effective monitoring and inspection techniques are required to minimise unscheduled shutdowns due to leakage in order to meet ever demanding production requirements. Since visual inspection of the sealing faces of flanged connections can only be accomplished during a shutdown of the system, it is vital that this process is made as simple as possible and therefore elimination of external corrosion must be a high priority.

If shut down is not an option, then an alternative method of inspection would be to use ultrasonic techniques, but again this process can be made much more complex and inaccurate if external corrosion is not controlled.

External corrosion protection of flanges and fastenings is therefore critical in order to be able to both monitor the system and provide more effective and realistic quality control and inspection procedures.

The [Belzona 3411](#) encapsulating system can not only be used to provide a complete corrosion protection for flanges, fastenings and associated pipes, but also as a preventive system which helps facilitating and improving further monitoring and inspection of flange faces.

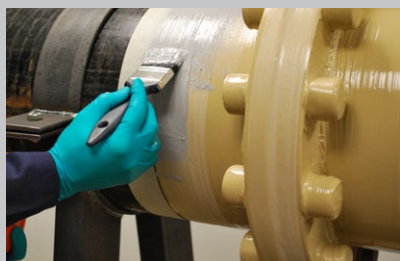

Belzona solutions for flanges

Repair of the flange face

The corrosive action of chemicals, crevice corrosion, galvanic corrosion and high pressure steam damage can result in the deterioration and subsequent leakage of flanges. Proven for over 10 years, the Belzona flange face forming technology eliminates the need for conventional cut and weld repair methods involving hot work and allows for a simple application in emergency situations, especially in areas with limited access such as on offshore platforms.

The [Belzona Flange Face Forming Kit](#) is a unique repair kit developed to aid the flange face forming technology in combating the common problems with mating surfaces of flanged joints such as heat distortion, corrosion and erosion. In conjunction with Belzona two-part epoxy repair composites (see product selector below), this flange repair kit provides a complete package solution which is simple and cost-effective to install.

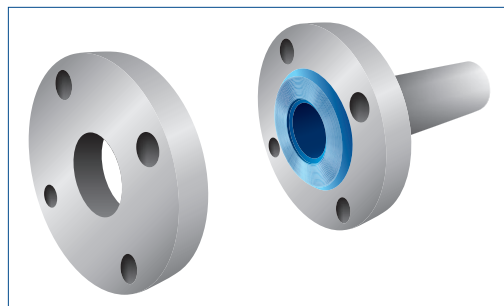

Flange face repaired with [Belzona Flange Face Forming Kit](#)

After years of successful flange face repairs, Belzona's unique flange face forming technology is now specified as a corrosion prevention solution for new flanges.

Applications for the Belzona flange face forming technology include:

- Protection of new and in service flange faces from corrosion
- Restoring of damaged flange faces
- Isolation of dissimilar metals from forming corrosion cells
- Can be used in conjunction with Belzona nozzle insert and vessel lining solutions to form a continuous internal lining film terminated outside the process environment

Flange protection with Belzona's encapsulating membrane

To answer external flange corrosion issues, Belzona has formulated a new peelable coating concept specifically designed for the protection of flanges, fastenings and associated pipework to exclude moisture and prevent crevice, galvanic and atmospheric corrosion.

This two-product system combines a tough flexible encapsulating topcoat, [Belzona 3411 \(Encapsulating Membrane\)](#), and a corrosion inhibitor, Belzona 8411.

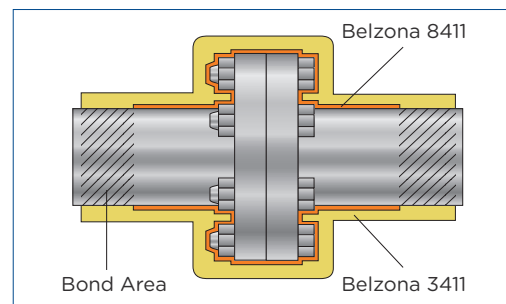

Belzona's flange encapsulation system

This tough and flexible system can be used to protect most flange shapes, sizes and configurations from corrosion and completely encapsulates the flange to exclude any moisture. Belzona 8411 also has release properties allowing the [Belzona 3411](#) topcoat to be peeled back from the joint to allow inspection.

When maintenance is required, the system can be simply cut open by using a sharp knife to cut through the membrane in the gap between the flange faces around the circumference of the flange. The membrane will be then be peeled back, exposing bolts and flanges. Once the required maintenance has been completed, the membrane will fold back to its original position and can be sealed with a further quantity of [Belzona 3411](#).

This system is easy to apply, does not require heat or any specialist tools and forms a tough elastic protective barrier when cured. ■

PRODUCT SELECTOR FOR FLANGE FACE FORMING

Products	Consistency	Erosion Resistance	Compressive Strength	Working Life at 15°C (60°F)	Full Mechanical Cure at 15°C (60°F)
Belzona 1111 (Super Metal)	Paste	High	High	25 min	36 hours
Belzona 1121 (Super XL-Metal)	Paste	High	High	60 min	72 hours
Belzona 1311 (Ceramic R-Metal)	Paste	Very high	High	25 min	36 hours
Belzona 1511 (Super HT-Metal)	Paste	High	High	40 min	24 hours
Belzona 4301 (Magma CR1 Hi-Build)	Paste	Medium	High	35 min	14 days

A SAFE FLANGE REPAIR

Belzona reforms 2" 150psi rated flange

In November 2014, an Oil and Gas major asset owner in the North Sea required a solution to rebuild the flange face of an inert gas generator system on an FPSO.

The existing lining had failed, leading to corrosion of the vessel internals and severe loss of metal on the adjacent flanges. The client was unable to use hot work and had a limited amount of time to carry out the application. Indeed, conventional cut and weld repair methods involve hot work and require replacement flanges which may not be available in emergency situations, especially in areas with limited access such as offshore platforms.

The [Belzona flange face forming](#) solution was chosen for this repair as it does not require hot work or replacement flanges and it can be rapidly performed minimising downtime. After the surface on the flange face was prepared, the selected Belzona material was mixed and applied to the damaged surface and to the former, pushing the material well into the prepared profile. Both surfaces were brought together and once the correct level was achieved the former was bolted to the flange. Once the product was sufficiently

cured the former was dismantled and bolts removed, leaving a perfectly formed sealing face on the original flange.

The application was carried out over a weekend and the entire solution, from first notification, was completed in less than a week. The client was very satisfied with the Belzona solution and commissioned more flanges to be reformed using the [Belzona flange face forming](#) technology. The vessel was quickly returned to service with minimum disruption to the production cycle. ■



Flange face highly corroded



Former in place with Belzona material



Flange face forming completed

BELZONA 3411 PUT TO THE TEST

Corrosion resistance

The corrosion resistance of the Belzona 3411 system has been proved by the salt spray test, used to assess a coating's ability to resist attack from a continuous salt fog. The salt chamber converts a 5% sodium chloride solution into a hot fog at 35°C (95°F).

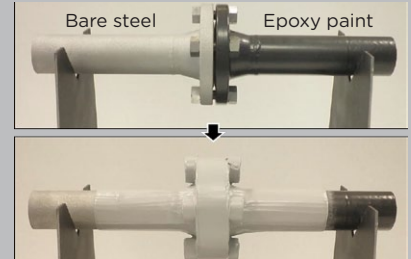

After 1,000 hours of exposure to the salt-fog atmosphere, no corrosion was reported under the encapsulating system. In comparison, the exposed steel part at the end of the flange showed a high level of corrosion.

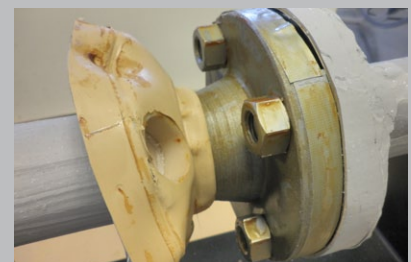

Adhesion

In order to provide a durable seal at the application extremities and exclude any moisture, the [Belzona 3411](#) system requires a good adhesion, particularly to manually prepared surfaces.

Adhesion testing has been performed on three manually prepared substrates according to ASTM D429/ISO8510-1 St 2. The results have shown a cohesive mode of failure on all substrates.

Substrate	Preparation	Adhesion	Failure Mode
Rusty carbon steel	Manual abrasion	6.6 pli 1.16 MPa	Cohesive
Epoxy paint	Manual abrasion	6.4 pli 1.12 MPa	Cohesive
Polyurethane paint	Manual abrasion	6.4 pli 1.12 MPa	Cohesive

BELZONA FLANGE FACE FORMING KIT

- Simple to use as all the necessary accessories are in one kit
- Contains 6 reusable plastic formers
- Lightweight allowing easy transportation to emergency situations and areas with limited access
- Minimised downtime as the kit eliminates the need for spare parts



52" FLANGE PROTECTED AND STILL IN SERVICE

Belzona 3411 solves corrosion problem in USA

In June 2014, the Plant Maintenance Manager of a chemical plant in South Louisiana, USA, contacted Belzona requiring an alternative flange corrosion protection solution.

The customer had a 52" flange on a vessel connecting to outlet piping that needed corrosion protection. To avoid corrosion between the flange faces, a previous protection solution consisting of fiberglass coverings was used on other vessels in the unit. Fiberglass offers excellent heat resistance, which makes it an interesting solution on a vessel. These materials can however be time-consuming and expensive to apply.

In order to avoid these drawbacks, the client was looking for an alternative and more cost-effective corrosion protective solution that allows for a simple installation, is suitable for all flange

sizes and shapes, and permits easy access for inspection purposes.

[Belzona 3411](#) was recommended as the system provides a complete corrosion protection for flanges, fastenings and associated pipes and can be easily applied and peeled back for maintenance purposes.

The application was carried out by the plant personnel in accordance with Belzona's application procedures. The customer saved several thousand dollars over the previous fiberglass system with easier installation. The unit was inspected 90 days after the installation and it looked as good as it did on day one. The client was very satisfied with the Belzona solution and is planning to use [Belzona 3411](#) on other flanges. ■

FOR MORE APPLICATIONS

Visit khia.belzona.com to access a comprehensive database of Belzona case studies collected over the years.

Belzona 3411

- » [XXIX, no. 119](#) - Tank Storage Provider
- » [XXVIII, no. 198](#) - Chemical Plant
- » [XXIX, no. 75](#) - Gas Distribution Company

Flange Face Forming

- » [XXIX, no. 89](#) - Oil & Gas
- » [XXIX, no. 87](#) - Oil & Gas
- » [XXIX, no. 80](#) - Oil & Gas
- » [XXVII, no. 46](#) - Hydropower Plant
- » [XXIV, no. 48](#) - Nuclear Power Plant
- » [XXIV, no. 7](#) - Metallurgy
- » [XXIII, no. 96](#) - Nuclear Power Station
- » [XXI, no. 57](#) - Corn Mill

Visit Belzona.com to find out more about turnkey solutions Belzona can offer to minimise downtime and extend your maintenance-free periods.

Belzona strives to provide a complete supply and apply package through its Global Distribution network. This network was specifically created to provide clients with direct access to materials, specialist application services, supervision and inspection services. It is Belzona's mission to meet specialist repair and maintenance needs in its target industries and markets worldwide.

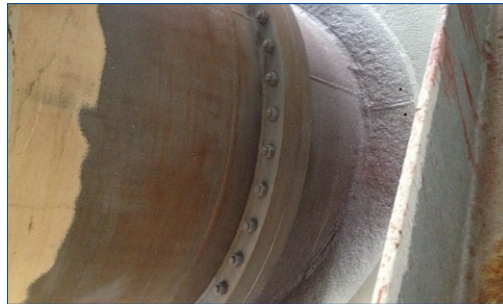

52" flange grit blasted



First layer of Belzona 3411 applied



Completed application on the flange



Flange in perfect condition after months in service



Issue No.

109



Click here to find your local Belzona Representative

